

The logo for PARPRO, with 'PAR' in black and 'PRO' in blue, all in a bold, sans-serif font.

Partners in Production and Design

LODESTAR SERIES

High Performance Network
Platforms For Tomorrow's
Networking Challenges
"The No Compromise Option"

A graphic of a tunnel formed by curved lines of binary code (0s and 1s) in shades of blue and green, receding into the distance.

TECHNOLOGY BRIEF

Lodestar Series

Introducing a series of high performance network platforms providing developers with deployment-ready solutions with a greater degree of flexibility.

Gone are the days of simple packet forwarding equipment. Today's network appliances must deal with a ridiculously high data bandwidth while handling many different protocols, flow and session tracking, and prioritization rules based on deep packet inspection. All the while keeping an eye out for suspicious activity. To top it off, all of these activities must be done in a real-time, low-latency manner or you run the risk of bogging down your network and disrupting your services. Solving these challenges places an enormous demand for processing power and I/O bandwidth on today's networking platforms.

PARPRO's Lodestar series of network platforms have been designed to meet the demanding needs of tomorrow's networks. We set out to design a family of products with these four important objectives:

- 1. Massive multi-cores processing solutions.** Multi-core processing is nothing new to the data communication world but the bandwidth demand required by today's feature requirements of IPv6 and 'application aware' processing is adding an enormous demand for computing power. PARPRO offers a variety of products from multi-core Intel™ server based processors to Cavium's OCTEON III MIPS64 processors that offer an astounding 48 processing cores.

2. **High capacity I/O.** Multi-core processing only solves half the problem. You need a way of moving the data into and out of these massive processing engines. A many core system will quickly become starved if you do not have properly matched I/O capability to keep the data flowing smoothly through the system. PARPRO offers a full range of I/O options from large arrays of 10/100/1000Mb based Ethernet to massive pipes supplying 10G, 40G and 100G of data throughput.
3. **Diverse selection of processing technologies.** When large multi-cores are not enough, the combination of a high capacity switch, hardware accelerators and raw processing power are used together to keep the data flowing. Many of the compute-intensive network functions are well defined and can benefit from hardware accelerators. PARPRO offers solutions with hardware TCAMs, encryption, decryption, compression and decompression engines.
4. **A compact, well designed, best-in-class integrated platform.** Rack space is a precious resource in data centers. Having a compact all-in-one solution will not only reduce your rack footprint, it will reduce overall power consumption when compared to using separate discrete network components.

The PARPRO Lodestar series is a revolutionary set of products that offer a solid mix of these objectives designed into best-in-class platforms providing unique solutions to a variety of today's networking challenges.

LODESTAR SERIES

CSW-1240

Trident II based
Server-Switch
Appliance

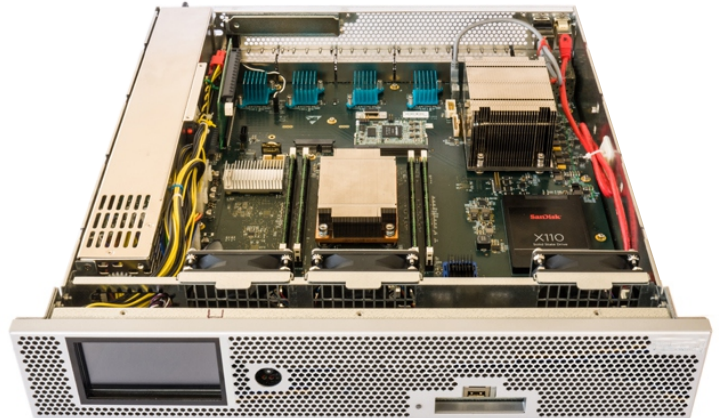

The PARPRO CSW-1240 Network Appliance combines the functionality of a server and a switch into a single, compact 2U 19-inch rack enclosure. It features an Intel Xeon E5-2680 Processor with up to 3.2GHz core clock rate and up to 32GB DDR3-1600 memory with ECC. One BCM56850 Ethernet switch and five BCM54680E transceivers provide 40 ports of 1000Base-T to the rear panel along with an additional 8x 10G SFP+ ports.

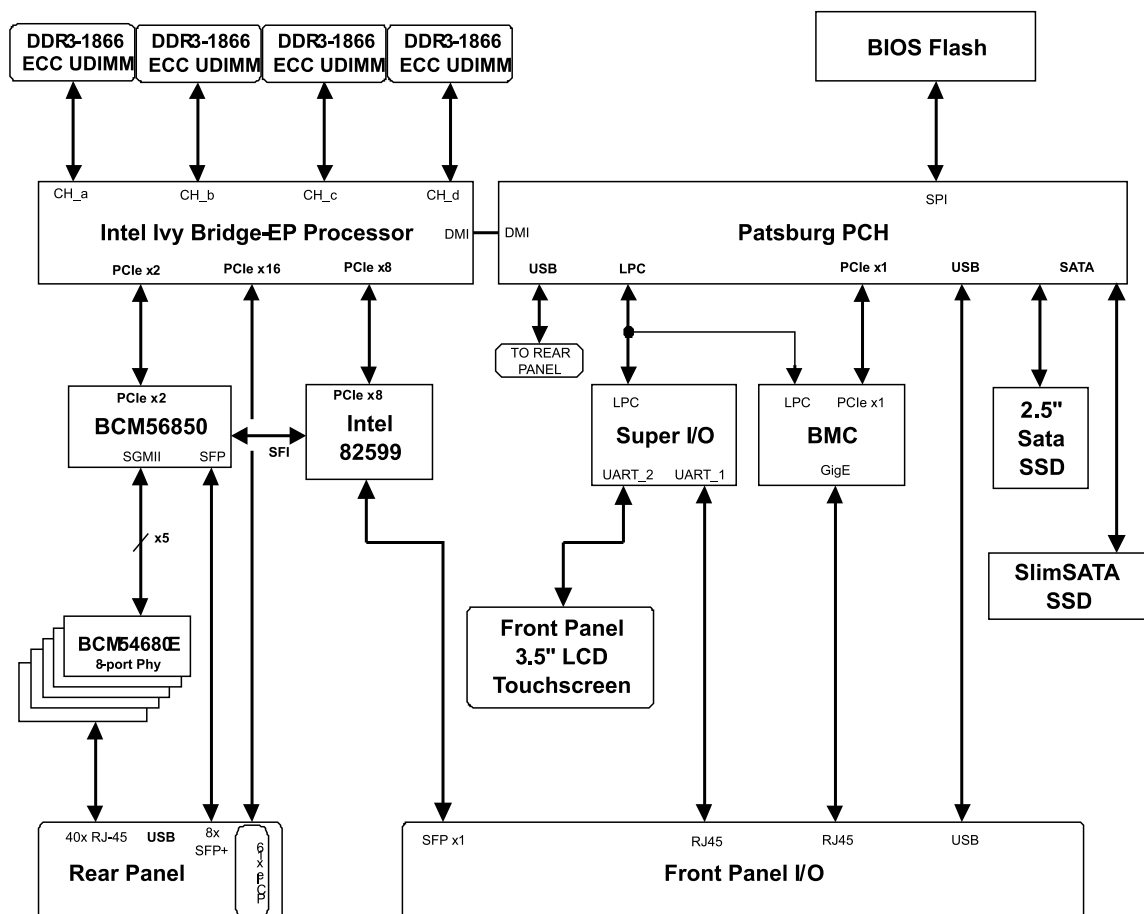

LODESTAR SERIES

N5R-100

1U Network Appliance

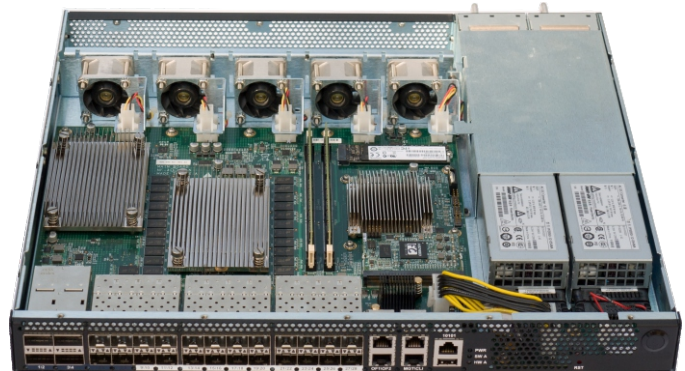

The PARPRO N5R-100 Network Appliance combines the functionality of a server and a network processor into a single compact 1U 19-inch rack enclosure. It features a 4th generation Intel Quad-Core i7-4700EQ Processor combined with an NP-5 EZchip network processor, and an external TCAM accelerator for additional lookup capabilities. The EZchip NP-5 provides 240GB traffic manager with up to 480Gbps peak processing data path and CoS classification.

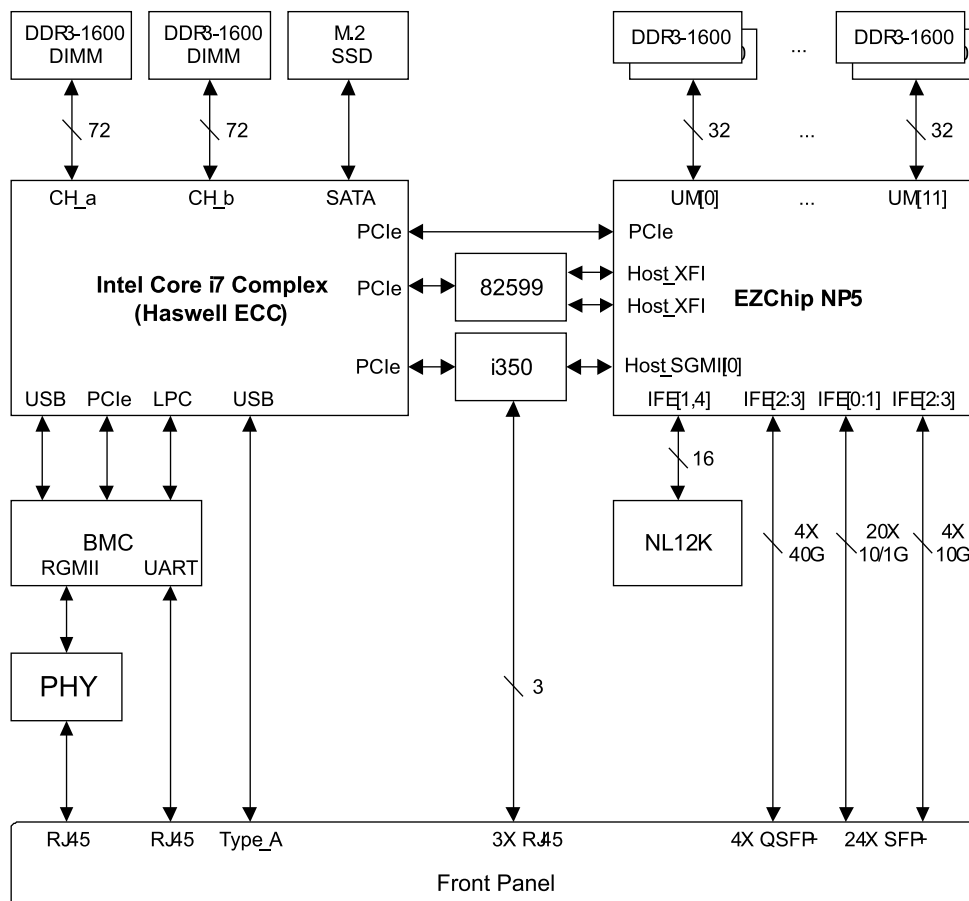

LODESTAR SERIES

RPE-130

PCI Express
Broadcom XLP II
Packet Processor Card

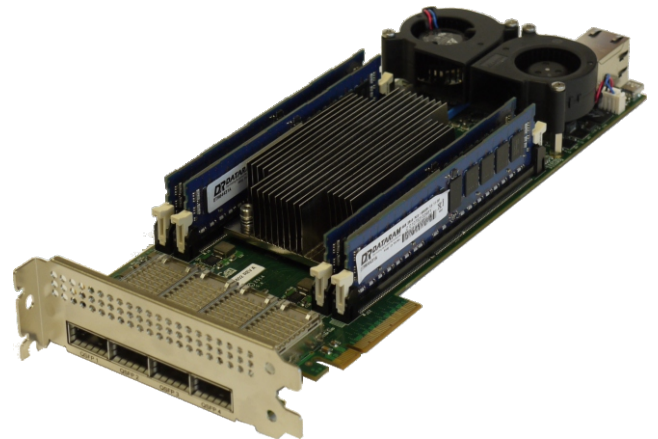

The PARPRO RPE-130 is a high-performance network processor PCI Express card. It features the Broadcom XLP9xx/7xx Network Processors supporting up to 16 cores running up to 1.8GHz core speed. The RPE-130 provides up to 128GB of quad-channel 72-bit wide DDR3 ECC memory running up to 2133MT/s. Four QSFP interfaces are provided on the front panel, supporting 40GbE or 10GbE I/O.

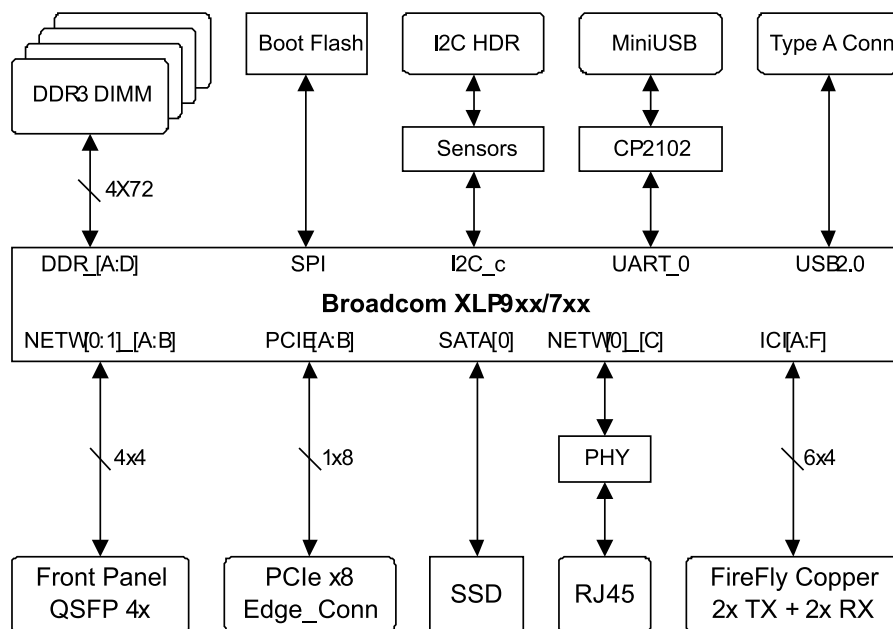

LODESTAR SERIES

O3E-110

PCI Express
Cavium OCTEON III

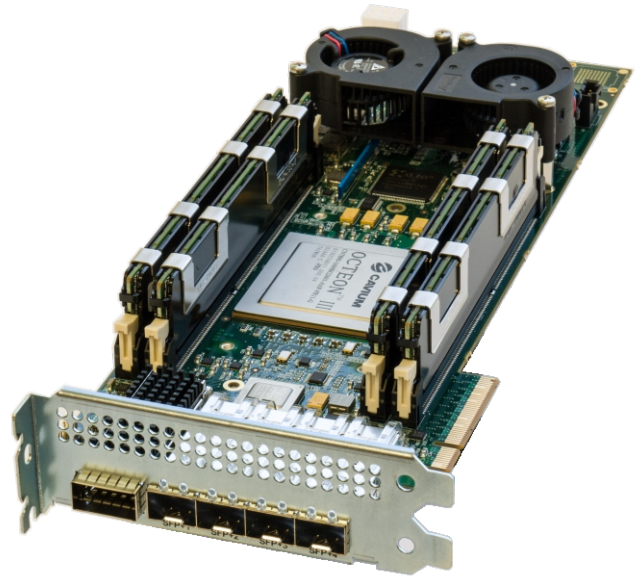

The PARPRO O3E-110 is a high-performance network processor PCI Express card based on the Cavium Networks OCTEON III processor. It features the CN78xx series packet processor with up to 48 cores running up to 2.0GHz core speed. Four channels of DDR3-2133 memory supporting up to 128GByte are available via full size DIMMs. The CN78xx series processor offers eight Quad-Lane Module (QLM) Serdes interfaces supporting 80G of high speed I/O. Four SFP+ and one QSFP+ module interfaces are provided on the PCIe front plate. Additional Serdes channels are available internally for I/O expansion and for coherent multi-board expansion.

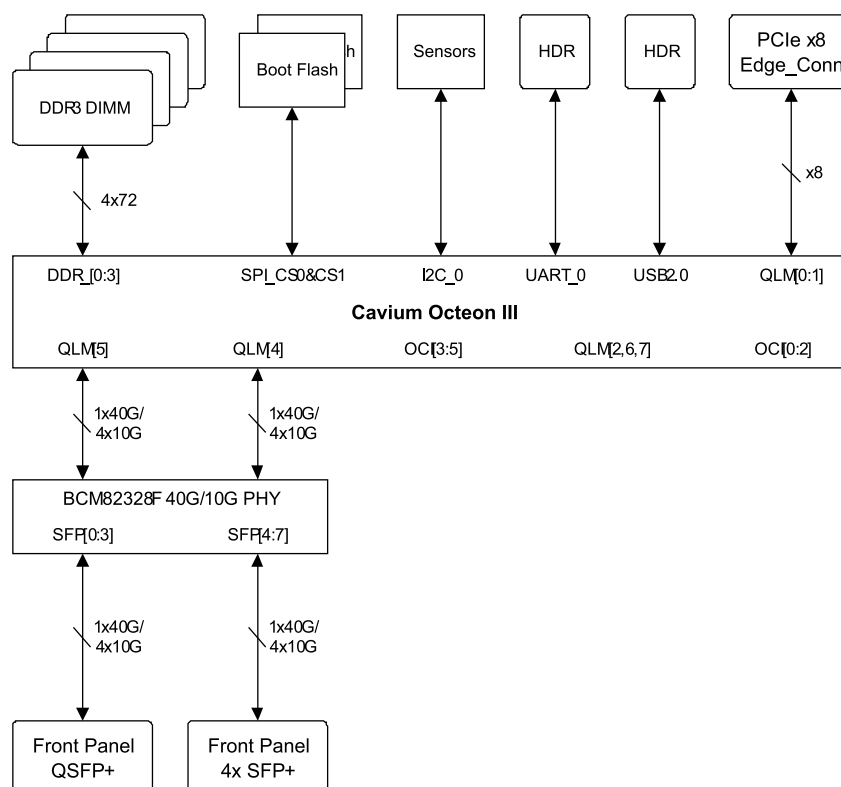



Partners in Production and Design

N. AMERICA HEADQUARTERS

PARPRO Embedded Systems (CA)
2772 Gateway Road, #102
Carlsbad, CA 92009
Tel: +1 (760) 931.7800

NEVADA - US

PARPRO Nevada
7390 Eastgate Road, #160
Henderson, NV 89011
Tel: +1 (702) 331.2700

MEXICO

PARPRO Mexico
Periférico Sur No. 1 Col. Obrera
Tijuana, Baja California México
C.P. 22180
Tel: +1 (664) 637.5602

TAIWAN

PARPRO TAIWAN
67-1, Dongyuan Road
Chungli Industrial Park, Taoyuan
Taiwan 32063
Tel: +886 3 452.5535

For General inquiries, please contact
1-844-PARPRO-1 or +1 (760) 931-7800
Email: sales@parpro.com